



## GENERAL INFORMATION

ColorSource Linear Pearl is a variable white-light LED wash fixture that utilises a mix of two different white LEDs that enable a user to set the colour temperature anywhere between 2700 K and 6500 K. The Pearl array includes the same great feature set and high quality construction as their full colour siblings including an impressively bright output and simple user interface.

Designed for installations that depend heavily on white light such as studios, houses of worship, and architectural installations, this array features flicker-free operation and an impressively smooth dimming curve.

### APPLICATIONS

- Houses of worship
- Universities and schools
- Studios
- Hospitality
- Retail
- Exhibition centres
- Meeting rooms

### PRODUCT FEATURES

- Available in three lengths
  - Linear 1 (0.5m) - one cell of control
  - Linear 2 (1m) - two cells of control
  - Linear 4 (2m) - four cells of control
- 2700 K to 6500 K variable white light
- Homogenised optics
- Simple user interface with seven-segment display
- powerCON in and thru power connections
- DMX in and thru (5-pin XLR or RJ45 connectors)
- RDM or local configuration
- LED droop compensation for consistent output
- Optically calibrated
- Tour-ready, aluminium housing

## ORDERING INFORMATION

### ColorSource Linear Pearl

PART NO.	DESCRIPTION
7414A1260	ColorSource Linear Pearl 1, XLR, Black
7414A1250	ColorSource Linear Pearl 1, RJ45, Black
7414A1261	ColorSource Linear Pearl 2, XLR, Black
7414A1251	ColorSource Linear Pearl 2, RJ45, Black
7414A1262	ColorSource Linear Pearl 4, XLR, Black
7414A1252	ColorSource Linear Pearl 4, RJ45, Black

Colour Options: Please use colour code suffix -1 for White or -5 for Silver Grey

Notes: ColorSource CE Linear luminaires ship with a pair of trunnions and a 1.8m PowerCON to bare ends power cable.

## PRODUCT SPECIFICATIONS (LINEAR 1/2/4)

**Source**

LED details	40 / 80 / 120 Lumileds LUXEON® Z LEDs
Max lumens	5,649 / 11,298 / 22,596
Lumens per watt	50 / 52 / 51
L70 rating (hours to 70% output)	36,000 hours (estimate pending testing data)

**Colour**

Colours used	Warm white, cool white
Colour temperature range	2700 K - 6500 K
Calibrated array	Yes
Red shift	No

**Optical**

Beam angle range	15 degrees
Gate size	N/A
Aperture size	N/A
Pattern projection	No
Pattern size	N/A
Camera flicker control/Hz range	1,200 Hz (default) and 25,000 Hz (via RDM)
Notes	Lenses are available for beam control. See accessories section below

**Control**

Input method	DMX-512 via 5-pin XLR or RJ45 connector
Protocols	DMX, RDM
Modes (footprint)	Variable Color Temperature: ICt (2) Direct: IWCS (4) 1 channel: I (1)
RDM configuration	Yes
UI type	7-segment address display
Local control	Yes
Onboard presets	Yes (12)
Onboard sequences	No
Onboard effects	No
Fixture to fixture control	Yes
Notes	Local level control via UI

**Electrical**

Voltage range	100V-240VAC, 50/60Hz
Input method	powerCON in and thru
Inrush	49A / 85.6A / 153A (first half-cycle) at 230V
Fixtures per circuit	10 fixture cells (16A max) on circuit, Sensor or Unison Relay Module or similar)
Wattage (typical / standby)	112W / 2.6W, 214W / 2.6W, 431W / 4.7W at 230V
Current draw	0.5A / 1.0A / 1.9A at 230V

**Thermal**

Ambient operating temp	0-40° C
Fan (controllable)	Yes (no)
Droop compensation	Yes
dB range	24.2 / 28.4 / 31dBa average at 1m
BTUs/hour	385 / 747 / 1,514

**Physical**

Materials	Die-cast aluminum and plastic
Color options	Black, white, silver or custom color
Mounting options	Yoke and floor
IP rating	IP20
Weight	2.9kg / 9.1kg / 17kg)
Included accessories	Trunnions, power cable
Notes	See accessories list for power cable options

**Warranty**

Full fixture	5 years
LED array	10 years

PRODUCT FEATURES



**ENDLESS LIGHT**

ColorSource Linear Pearl fixtures are designed to mount end-to-end without gaps in light for a smooth, linear wash.



**WARM TO COOL**

Bright white light from 2700 K to 6500 K

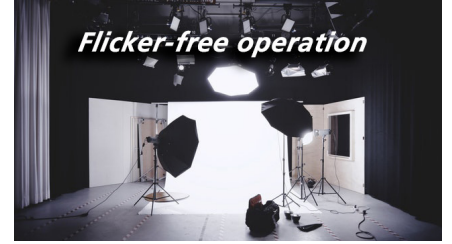

**GREAT FOR STUDIOS**

With refresh rates up to 25,000Hz, there is no need to worry about flicker on camera

COLOR METRIC INFORMATION

TM-30-15 3200K - COLORSOURCE LINEAR PEARL

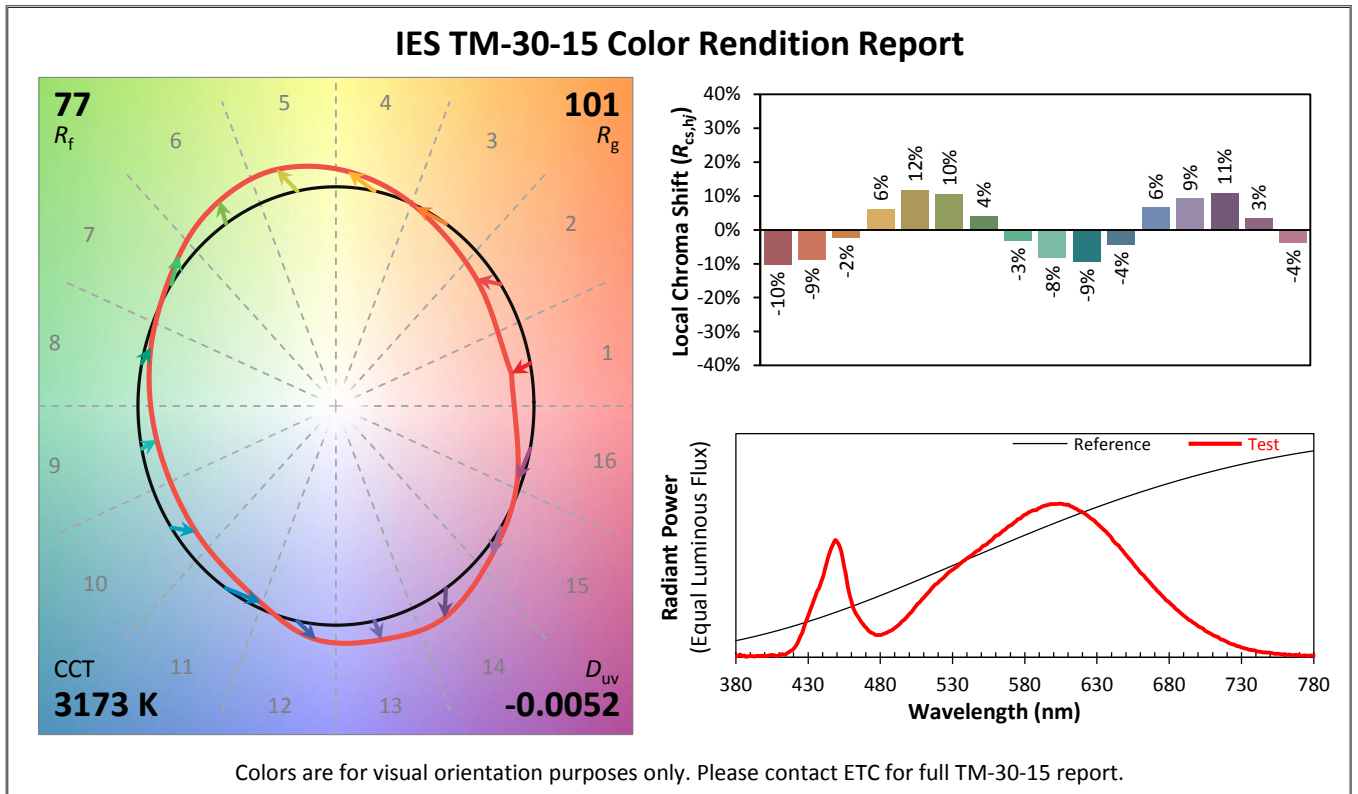

COLOR METRIC INFORMATION

TM-30-15 3200K - COLORSOURCE LINEAR PEARL

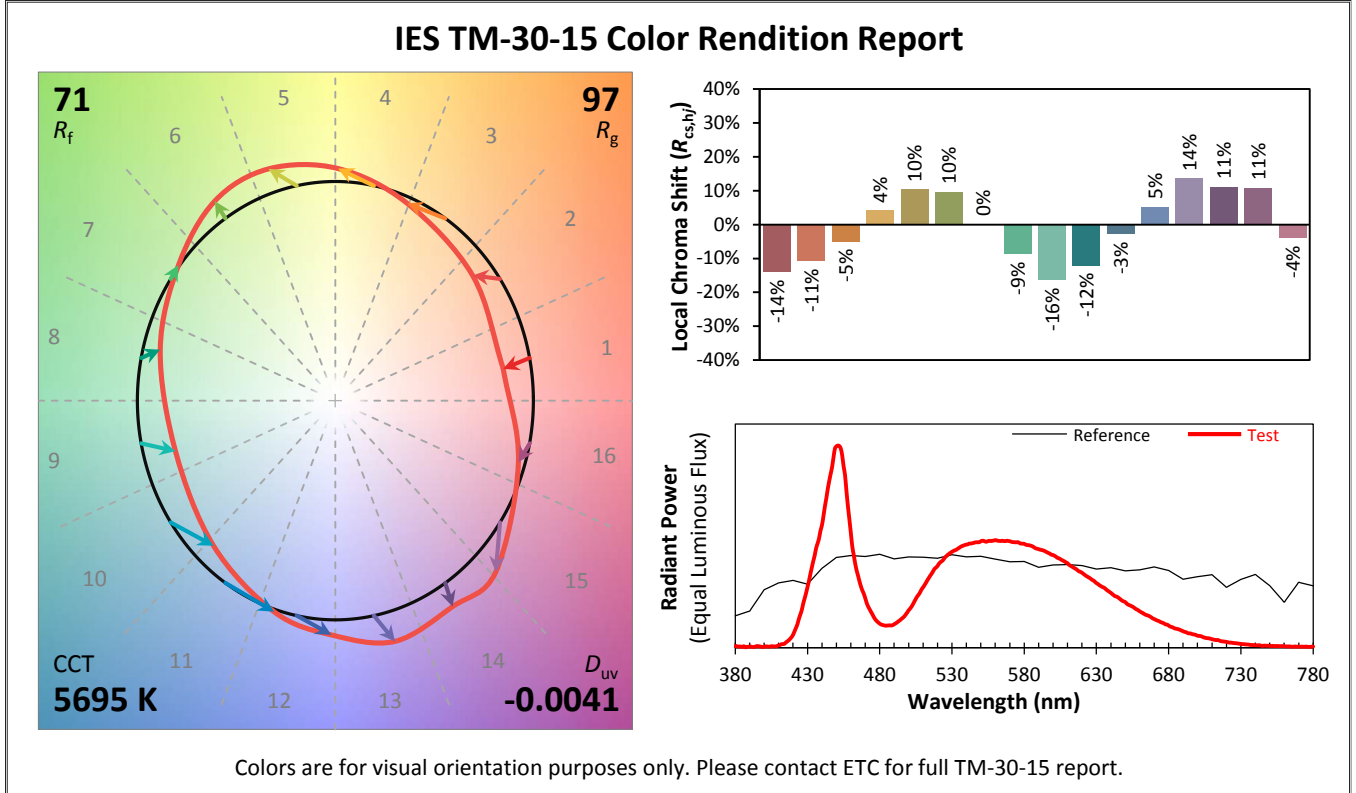

Additional Color Metrics

	CS LINEAR PEARL 3200K	CS LINEAR PEARL 5600K
CRI $R_a$ ( $R_g$ )	81 (18)	74 (3)
TLCI	60	49

PHOTOMETRY

COLORSOURCE LINEAR PEARL PHOTOMETRY NOTE:

The Photometry information shown below is for the Linear 1 (0.5 meter) fixture. Each longer Linear fixture is made up of multiple half-meter sections.

When calculating photometry for the Linear 2 multiply the information shown below by two. When calculating photometry for the Linear 4, multiply the information below by four.

Due to the physical properties of linear products, this is the best method for determining photometry for longer fixtures.

For a detailed explanation of linear photometry, please visit: <http://www.etconnect.com/WorkArea/DownloadAsset.aspx?id=10737489380>

For .ies files or lensing information, use the ColorSource PAR files and assume you have multiple fixtures (for the Linear 2 and the Linear 4) hung 0.5 meters on center.

ColorSource Linear Pearl 1

Mode	Degree	Candela	Field Lumens	Beam Lumens	Power Consumption	Lumens Per Watt
CT Mode (3200 K)	27.2	50,316	3,261	1,868	82.0W	40
CT Mode (5600 K)	27.2	43,061	2,791	1,598	57.3W	49
Direct Mode Full (4000 K)	27.2	75,732	4,908	2,811	113.5W	43

Metric conversions: For meters, multiply feet by 0.3048  
For lux, multiply footcandles by 10.76

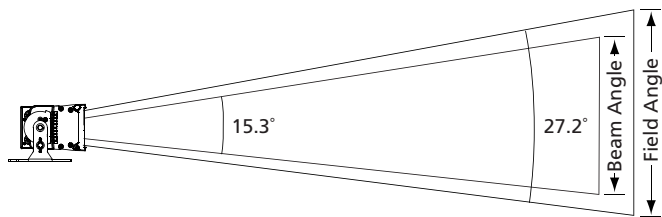

Throw Distance (d)	10ft	15ft	20ft	25ft
	3.0m	4.6m	6.1m	7.6m
Field Diameter	4.8ft 1.5m	7.3ft 2.2m	9.7ft 2.7m	12.1ft 3.7m
Illuminance (fc)	757	337	189	121
Illuminance (lux)	8,152	3,623	2,038	1,304

To determine center beam illumination in footcandles at any throw distance, divide candela by the throw distance squared

For field diameter at any distance, multiply distance by 0.484  
For beam diameter at any distance, multiply by 0.269

Candela Plot

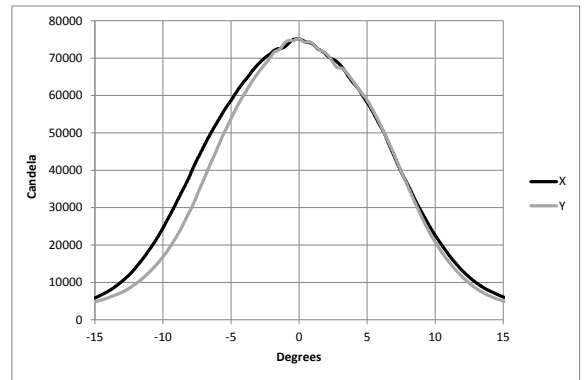

Iso-Illuminance Diagram (Flat Surface Distribution)

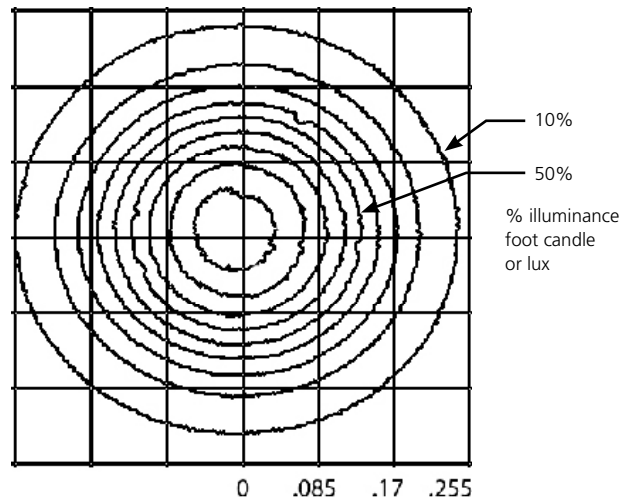

ADDITIONAL ORDERING INFORMATION

Secondary Lens Options

<b>PART NO.</b>	<b>DESCRIPTION:</b> The following lenses are cut for ColorSource luminaires and create round, linear or oblong field patterns as described below. These lenses are not sized for use in Selador® Classic fixtures.	
<b>HORIZONTAL</b>		
7414K1001	Very Narrow Linear Horizontal lens	Linear lenses may be combined to create desired field size
7414K1003	Narrow Linear Horizontal lens	
7414K1005	Medium Linear Horizontal lens	
7414K1007	Wide Linear Horizontal lens	
7414K1009	Extra Wide Linear Horizontal lens	
<b>VERTICAL</b>		
7414K1002	Very Narrow Linear Vertical lens	
7414K1004	Narrow Linear Vertical lens	
7414K1006	Medium Linear Vertical lens	
7414K1008	Wide Linear Vertical lens	
7414K1010	Extra Wide Linear Vertical lens	
<b>ROUND</b>		
7414K1011	Very Narrow Round Lens	
7414K1012	Narrow Round Lens	
7414K1013	Medium Round Lens	
7414K1014	Wide Round Lens	
7414K1015	Extra Wide Round Lens	

Typical Lens Field Profiles

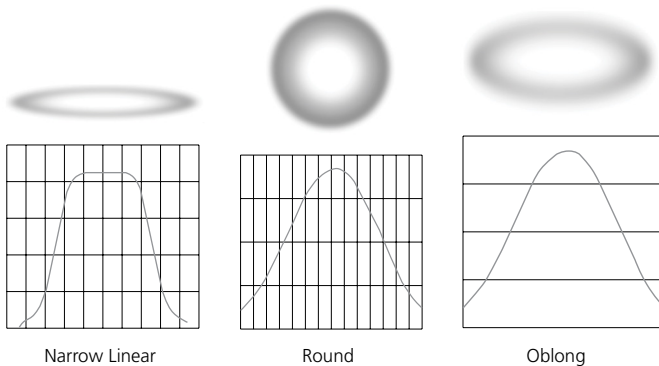

ADDITIONAL ORDERING INFORMATION

Power cables Power Thru Jumpers

Power thru jumpers connect to luminaire's output (thru) connector to provide power to a successive luminaire in-line

PART NO.	DESCRIPTION
7410B7013	1.8m PowerCON to bare ends power input cable (Replacement)
7410K1101	1m PowerCON to bare ends power thru cable 3x1mm2
7410K1102	1m PowerCON to PowerCON power thru cable 3x1mm2
7410K1103	2m PowerCON to PowerCON power thru cable 3x1mm2
7410K1104	5m PowerCON to PowerCON power thru cable 3x1mm2
7410K1105	1m twin jumper cable with both PowerCON to PowerCON and DMX (XLR5) control cable
7410K1106	2m twin jumper cable with both PowerCON to PowerCON and DMX (XLR5) control cable
7410K1107	5m twin jumper cable with both PowerCON to PowerCON and DMX (XLR5) control cable

Luminaire Accessories

PART NO.	DESCRIPTION
7414K1017	ColorSource Linear 1 Yoke Kit, Black
7414K1018	ColorSource Linear 1 Double-Yoke Kit, Black
7414K1020	ColorSource Linear Barndoor (2x 0.5m sections), Black
7414K1019	ColorSource Linear Louvre (0.5m section), Black
7414K1023	ColorSource Linear Diffusion Spacer (Replacement) (Shipping with Linear 2 and Linear 4 fixtures)

NOTES ABOUT LED LUMINAIRES

All LED sources experience some lessening of light output and some colour shift over time. LED output will vary with thermal conditions. Thermal conditions can be affected by ambient temperatures and orientation. Based on the LED manufacturer's B50 L70 specification, a ColorSource luminaire will achieve ~70% of its initial output after 20,000 hours of typical usage. In individual situations, LEDs will be used for different durations and at different levels. This can eventually lead to minor alterations in colour performance, necessitating slight adjustments to presets, cues or programs.

CONTROL

DMX Input Channel Profiles

DMX Channel	ct (Variable colour temperature)	dir (Direct)	1ch (One channel)
1	Intensity	Intensity	Intensity
2	Colour temperature	Warm white	
3		Cool white	
4		Strobe*	

\*Use DMX values of 0 or 255 for no strobe. Use values of 1-254 to increase the strobe rate from 1 per second up to 33 per second.

PHYSICAL

ColorSource Linear Pearl Pearl Dimensions

MODEL	HEIGHT	WIDTH	DEPTH
	mm	mm	mm
Linear 1	109	499	153
Linear 2	109	1000	153
Linear 4	109	1991	153

\*Does not include mounting hardware

ColorSource Linear Pearl Pearl Weights

MODEL	WEIGHT*	SHIPPING WEIGHT
	kg	kg
Linear 1	2.9	3.6
Linear 2	9.1	10.7
Linear 4	17.0	18.1

\*Does not include mounting hardware

COLORSOURCE LINEAR PEARL 1

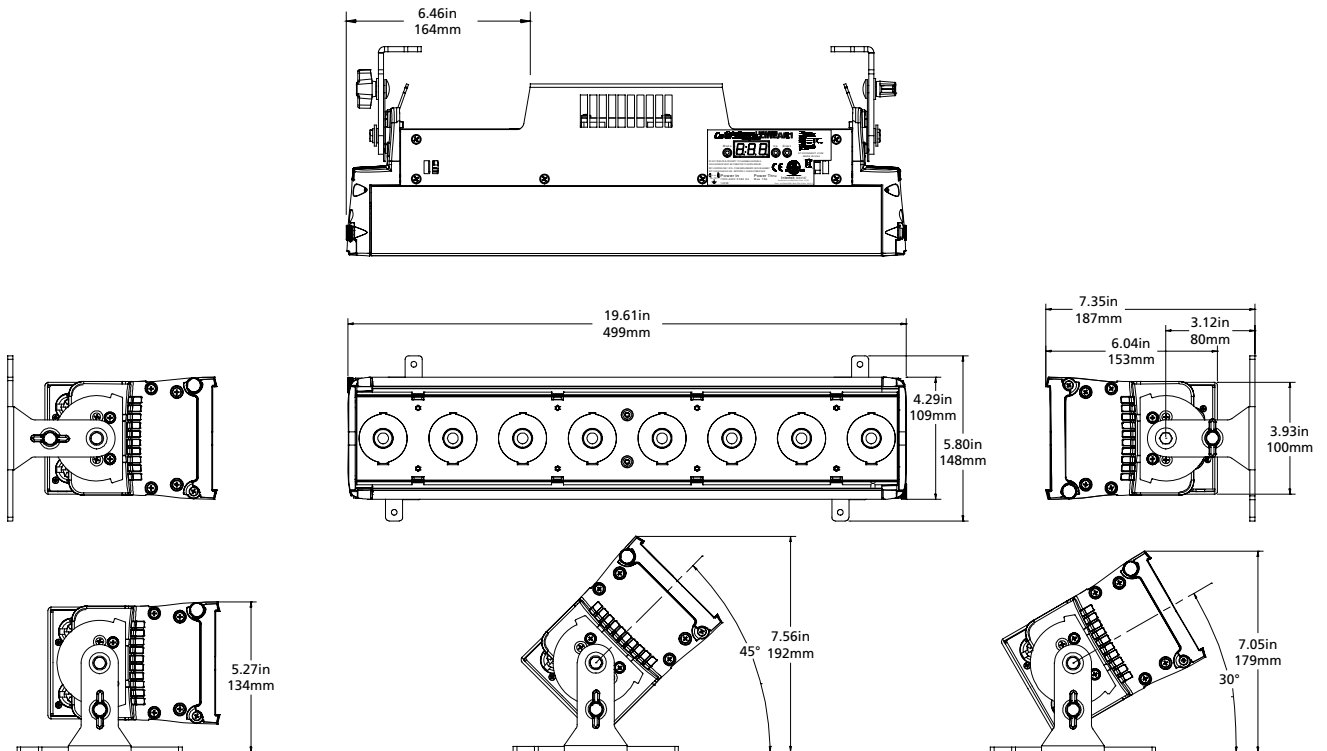

PHYSICAL

COLORSOURCE LINEAR PEARL 2

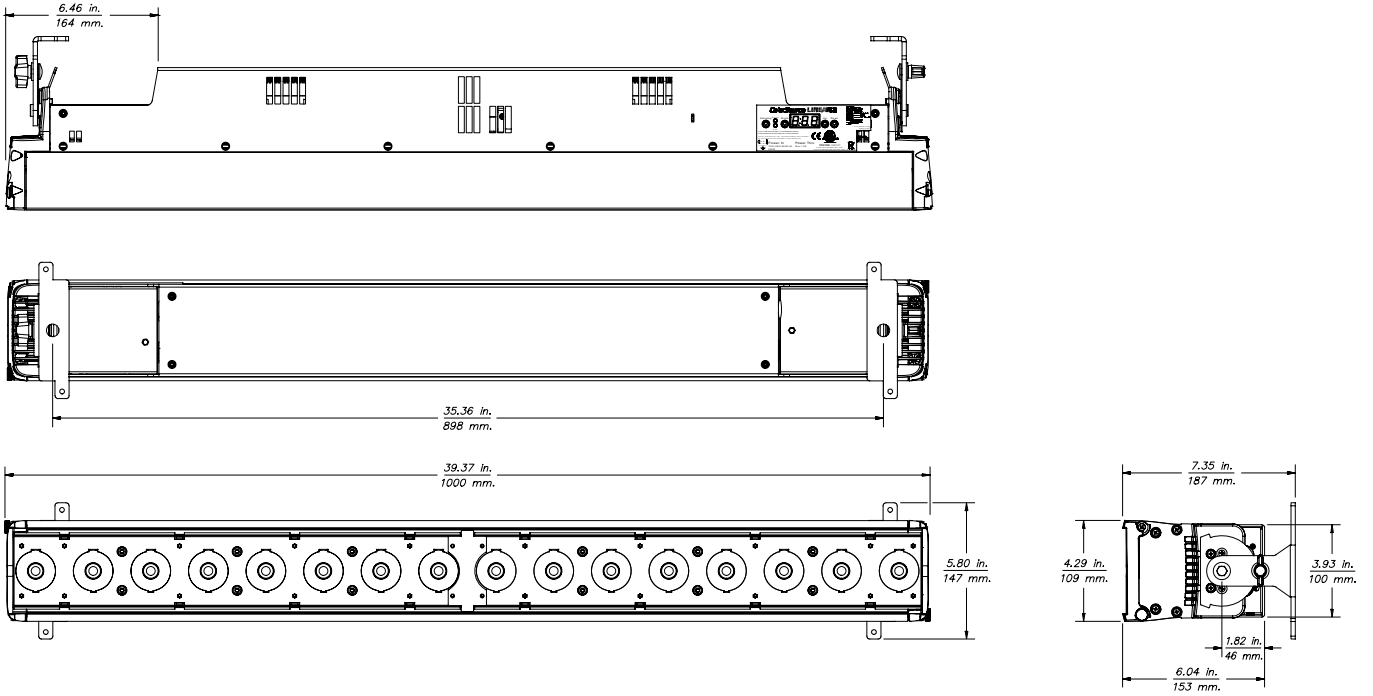

COLORSOURCE LINEAR PEARL 4

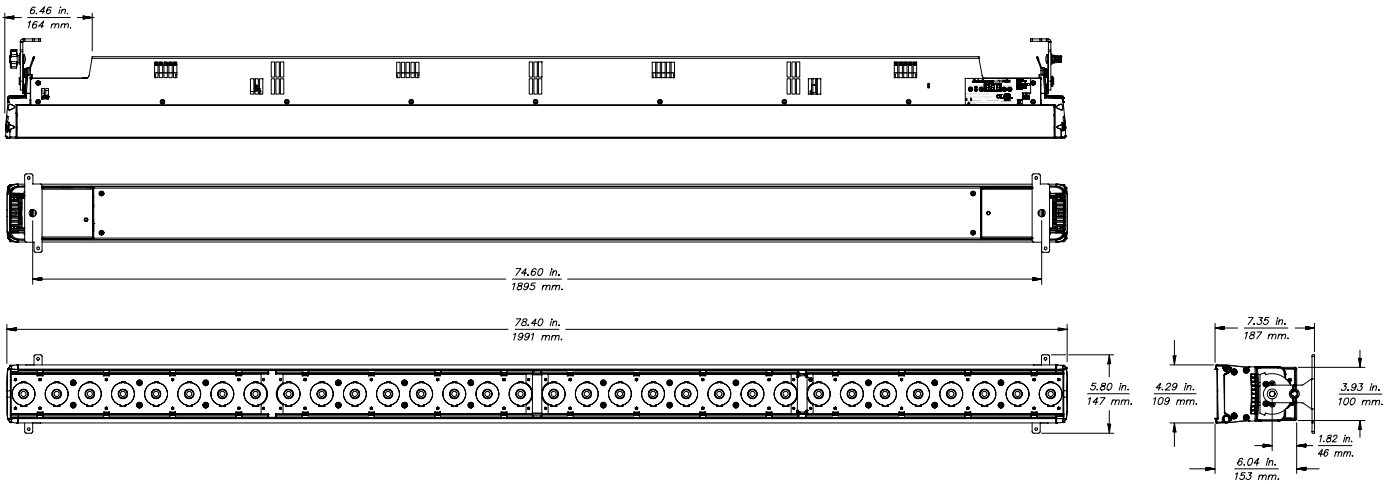

**Corporate Headquarters** • 3031 Pleasant View Rd, PO Box 620979, Middleton WI 53562 0979 USA • +1 608 831 4116  
**London, UK** • Unit 26-28, Victoria Industrial Estate, Victoria Road, London W3 6JU, UK • +44 (0) 20 8896 1000  
**Rome, IT** • Via Bruno Pontecorvo 10, 00012 Guidonia Montecelio, Roma, Italy • +39 06 32 111 683  
**Holzkirchen, DE** • Ohmstrasse 3, 83607 Holzkirchen, Germany • +49 (80 24) 47 00-0  
**Hong Kong** • Room 1801, 18/F, Tower 1 Phase 1, Enterprise Square, 9 Sheung Yuet Road, Kowloon Bay, Kowloon, Hong Kong • +852 2799 1220  
**Web** • etconnect.com • Copyright©2018 ETC. All Rights Reserved. All product information and specifications subject to change. 7414L1003-GB Rev A 05/18